



AVIATION FUELING PRODUCTS

Hewitt Catalog





AVIATION FUELING PRODUCTS

Table of Contents

Aviation Fueling Hoses	1-0	Aviation Fueling Nozzles	7-0
4113 Permanent Fitting	1-1	Osprey	7-1
4113 Reusable Coupling	1-2	Osprey S	7-2
4113CT Permanent Cold Weather Fitting	1-3	Falcon Nozzle	9-0
JacRiser Fueling Hoses	2-0	Falcon Manual	9-1
5500 JacRiser	2-1	Falcon Quick Disconnect	9-2
Coupling	3-0	Swivels	10-0
Aviation Qualified Couplings	3-1	Aviation Swivel	10-1
Protective Coils	4-0	Aviation Spouts	11-0
Spiral Casings	4-1	Falcon Spout Assembly	11-1
Deadman Hoses	5-0	Aviation Strainer	12-0
Twin 1/4" Hose	5-1	Aviation NPT Strainer	12-1
Sensing Hoses	6-0		
Twin 3/8" Hoses	6-1		





Aviation Fueling Hoses



4113 Permanent



4113 Permanent Fitting aviation fueling hose recommended for all types of riser deck, reel, and hydrant hose applications.

- Used for commercial and private aircraft
- Resistant to jet fuel and higher aromatic aviation gasolines
- Compatible with use on hydrant service
- Meets EI 1529, 7th Edition, 2014 and European Standard EN ISO 1825 (2011), Type C, Grade 2, and NPFA 407
- Operating temperature -22 °F to +149 °F (-30 °C to +65 °C)
- Recommended for all types of riser deck, reel, and hydrant hose applications
- All aviation hose assemblies are 100% hydrostatic tested to 600 PSI and inspected for electrical continuity
- Every hose receives a unique serial number and test certificate



Specifying Information

MODEL NO.	DESCRIPTION	SHIPPING WEIGHT LBS (KG)
1" HOSES		
CP160024HABA	1" x 2' HEW 4113 MXM NPT BR NR	1.24 (0.6)
CP160180HABA	1" x 15' HEW 4113 MXM NPT BR NR	10.0 (4.5)
CP160360HABA	1" x 30' HEW 4113 MXM NPT BR NR	20.0 (9.1)
CP160420HABA	1" x 35' HEW 4113 MXM NPT BR NR	23.0 (10.5)
CP160472HABA	1" x 39' 4" HEW 4113 MXM NPT BR NR	25.0 (11.3)
CP160480HABA	1" x 40' HEW 4113 MXM NPT BR NR	26.0 (11.8)
CP160588HABA	1" x 49' HEW 4113 MXM NPT BR NR	30.4 (13.8)
CP160600HABA	1" x 50' HEW 4113 MXM NPT BR NR	32.0 (14.5)
CP160720HABA	1" x 60' HEW 4113 MXM NPT BR NR	38.0 (17.3)
CP160792HABA	1" x 66' HEW 4113 MXM NPT BR NR	42.0 (19.1)
CP160900HABA	1" x 75' HEW 4113 MXM NPT BR NR	48.0 (21.8)
CP160960HABA	1" x 80' HEW 4113 MXM NPT BR NR	51.0 (23.1)
CP161080HABA	1" x 90' HEW 4113 MXM NPT BR NR	57.0 (25.9)
CP161200HABA	1" x 100' HEW 4113 MXM NPT BR NR	63.0 (28.6)
CP161380HABA	1" x 115' HEW 4113 MXM NPT BR NR	71.3 (32.4)
CP161560HABA	1" x 130' HEW 4113 MXM NPT BR NR	80.6 (36.6)
1 1/4" HOSES		
CP200600HABA	1 1/4" x 50' HEW 4113 MXM NPT BR NR	42.0 (19.1)
CP200660HABA	1 1/4" x 55' HEW 4113 MXM NPT BR NR	45.0 (20.1)
CP200792HABA	1 1/4" x 66' HEW 4113 MXM NPT BR NR	54.0 (24.5)
CP200840HBBA	1 1/4" x 70' HEW 4113 MXF NPT BR NR	57.0 (25.9)
CP200900HABA	1 1/4" x 75' HEW 4113 MXM NPT BR NR	61.0 (27.8)
CP201176HABA	1 1/4" x 98' HEW 4113 MXM NPT BR NR	77.4 (35.2)
CP201200HBBA	1 1/4" x 100' HEW 4113 MXF NPT BR NR	81.0 (36.8)
CP201200HABA	1 1/4" x 100' HEW 4113 MXM NPT BR NR	81.0 (36.8)
1 1/2" HOSES		
CP240024HABA	1 1/2" x 2' HEW 4113 MXM NPT BR NR	1.7 (0.8)
CP240108HABA	1 1/2" x 9' HEW 4113 MXM NPT BR NR	11.0 (5.0)
CP240120HABA	1 1/2" x 10' HEW 4113 MXM NPT BR NR	12.0 (5.5)
CP240600HABA	1 1/2" x 50' HEW 4113 MXM NPT BR NR	51.0 (23.2)
CP240720HABA	1 1/2" x 60' HEW 4113 MXM NPT BR NR	61.0 (27.8)
CP240780HBBA	1 1/2" x 65' HEW 4113 MXF NPT BR NR	66.0 (30.0)
CP240792HABA	1 1/2" x 66' HEW 4113 MXM NPT BR NR	67.0 (30.5)
CP240840HABA	1 1/2" x 70' HEW 4113 MXM NPT BR NR	71.0 (32.3)
CP240900HABA	1 1/2" x 75' HEW 4113 MXM NPT BR NR	76.0 (34.5)
CP241020HABA	1 1/2" x 85' HEW 4113 MXM NPT BR NR	85.0 (38.6)
CP241200HABA	1 1/2" x 100' HEW 4113 MXM NPT BR NR	100.0 (45.5)
CP241200HBBA	1 1/2" x 100' HEW 4113 MXF NPT BR NR	100.0 (45.5)

MODEL NO.	DESCRIPTION	SHIPPING WEIGHT LBS (KG)
CP240420HABA	1 1/2" x 35' HEW 4113 MXM NPT BR NR	36.0 (16.4)
CP240684HABA	1 1/2" x 57' HEW 4113 MXM NPT BR NR	49.0 (22.3)
CP240780HABA	1 1/2" x 65' HEW 4113 MXM NPT BR NR	66.0 (30.0)
CP241368HABA	1 1/2" x 114' HEW 4113 MXM NPT BR NR	98.0 (44.5)
CP241800HABA	1 1/2" x 150' HEW 4113 MXM NPT BR NR	129.0 (58.6)
2" HOSES		
CP320120HABA	2" x 10' HEW 4113 MXM NPT BR NR	16.0 (7.3)
CP320134HABA	2" x 11.17' HEW 4113 MXM NPT BR NR	13.4 (6.1)
CP320144HABA	2" x 12' HEW 4113 MXM NPT BR NR	19.0 (8.6)
CP320180HABA	2" x 15' HEW 4113 MXM NPT BR NR	23.0 (10.5)
CP320197HABA	2" x 16' 5" HEW 4113 MXM NPT BR NR	24.0 (10.9)
CP320216HABA	2" x 18' HEW 4113 MXM NPT BR NR	26.0 (11.8)
CP320240HABA	2" x 20' HEW 4113 MXM NPT BR NR	29.0 (13.2)
CP320420HABA	2" x 35' HEW 4113 MXM NPT BR NR	49.0 (22.3)
CP320480HABA	2" x 40' HEW 4113 MXM NPT BR NR	55.0 (25.0)
CP320564HABA	2" x 47' HEW 4113 MXM NPT BR NR	56.4 (25.6)
CP320600HABA	2" x 50' HEW 4113 MXM NPT BR NR	68.0 (30.9)
CP320600HBBA	2" x 50' HEW 4113 MXF NPT BR NR	68.0 (30.9)
CP320684HABA	2" x 57' HEW 4113 MXM NPT BR NR	68.4 (31.1)
CP320720HABA	2" x 60' HEW 4113 MXM NPT BR NR	81.0 (36.8)
CP320792HABA	2" x 66' HEW 4113 MXM NPT BR NR	89.0 (40.5)
CP320900HABA	2" x 75' HEW 4113 MXM NPT BR NR	101.0 (45.9)
2 1/2" HOSES		
CP400096HABA	2 1/2" x 8' HEW 4113 MXM NPT BR NR	19.0 (8.6)
CP400108HABA	2 1/2" x 9' HEW 4113 MXM NPT BR NR	20.0 (9.1)
CP400120HBBA	2 1/2" x 10' HEW 4113 MXF NPT BR NR	22.0 (10.0)
CP400120HABA	2 1/2" x 10' HEW 4113 MXM NPT BR NR	22.0 (10.0)
CP400144HABA	2 1/2" x 12' HEW 4113 MXM NPT BR NR	25.0 (11.4)
CP400156HABA	2 1/2" x 13' HEW 4113 MXM NPT BR NR	27.0 (12.3)
CP400192HABA	2 1/2" x 16' HEW 4113 MXM NPT BR NR	32.0 (14.5)
CP400197HABA	2 1/2" x 16' 5" HEW 4113 MXM NPT BR NR	33.0 (15.0)
CP400420HABA	2 1/2" x 35' HEW 4113 MXM NPT BR NR	64.0 (29.1)
CP400480HABA	2 1/2" x 40' HEW 4113 MXM NPT BR NR	73.0 (33.2)
CP400600HBBA	2 1/2" x 50' HEW 4113 MXF NPT BR NR	90.0 (40.9)
CP400600HABA	2 1/2" x 50' HEW 4113 MXM NPT BR NR	90.0 (40.9)
CP400660HABA	2 1/2" x 55' HEW 4113 MXM NPT BR NR	98.0 (44.5)
CP400720HABA	2 1/2" x 60' HEW 4113 MXM NPT BR NR	106.0 (48.2)
CP400084HABA	2 1/2" x 7' HEW 4113 MXM NPT BR NR	17.0 (7.7)
CP400118HABA	2 1/2" x 9' 3" HEW 4113 MXM NPT BR NR	20.0 (9.1)



WARNING: Cancer and Reproductive Harm - www.P65Warnings.ca.gov

4113 Permanent Fitting aviation fueling hose recommended for all types of riser deck, reel, and hydrant hose applications.

MODEL NO.	DESCRIPTION	SHIPPING WEIGHT LBS (KG)
CP400132HABA	2 1/2" x 11' HEW 4113 MXM NPT BR NR	34.0 (15.5)
CP400180HABA	2 1/2" x 15' HEW 4113 MXM NPT BR NR	30.0 (13.6)
CP400240HABA	2 1/2" x 20' HEW 4113 MXM NPT BR NR	39.0 (17.7)
CP400684HABA	2 1/2" x 57' HEW 4113 MXM NPT BR NR	100.0 (45.5)
CP401200HBBA	2 1/2" x 100' HEW 4113 MXF NPT BR NR	174.0 (79.1)
3" HOSES		
CP480096HABA	3" x 8' HEW 4113 MXM NPT BR NR	28.0 (12.7)
CP480108HABA	3" x 9' HEW 4113 MXM NPT BR NR	31.0 (14.1)
CP480120HABA	3" x 10' HEW 4113 MXM NPT BR NR	34.0 (15.5)
CP480132HABA	3" x 11' HEW 4113 MXM NPT BR NR	36.0 (16.4)
CP480144HABA	3" x 12' HEW 4113 MXM NPT BR NR	39.0 (17.7)
CP480168HABA	3" x 14' HEW 4113 MXM NPT BR NR	44.0 (20.0)
CP480180HABA	3" x 15' HEW 4113 MXM NPT BR NR	46.0 (20.9)
CP480240HABA	3" x 20' HEW 4113 MXM NPT BR NR	59.0 (26.8)
CP480360HBBA	3" x 30' HEW 4113 MXF NPT BR NR	85.0 (38.6)
CP480600HBBA	3" x 50 FT HEW 4113 MXF NPT BR NR	136.0 (61.8)
CP480600HABA	3" x 50' HEW 4113 MXM NPT BR NR	136.0 (61.8)
CP480720HABA	3" x 60' HEW 4113 MXM NPT BR NR	162.0 (73.6)

Construction

Tube	Black nitrile synthetic rubber
Cover	Black neoprene static dissipating/static conductive synthetic rubber (wrapped finish)
Reinforcement	Spiral-plyed (4) synthetic fabric and one nylon breaker
Couplings	Permanent brass internally expanded fittings - male and female NPT (swivel nut) Reusable 4-bolt aluminum clamp fittings - male and female, NPT and BSP threads - all females have swivel nuts - available with brass, tin plated brass, and stainless inserts

Order Guide (Ex. CP320600HABA)

AVIATION HOSE SIZE - CPSS

3/4" = CP12	2" = CP32
1" = CP16	2 1/2" = CP40
1 1/4" = CP20	3" = CP48
1 1/2" = CP24	4" = CP64

HOSE LENGTH (IN INCHES) - LLLL

0600 = 50 feet 0 inches
0606 = 50 feet 6 inches

AVIATION HOSE - H, C OR J

H = 4113 Aviation Hose
C = 4113CT Cold Temp
J = 5500 JacRiser Hose

NOTE:

If special, the next two digits will be used sequentially first using numbers (0-9) then using Alpha (A-Z). Special fittings or special materials will be described in the fab/shipping instructions section of the factory order. See separate assembly drawing for each special assembly number.

FITTING STYLE - S

A = Male x Male NPT Not Reusable
B = Male x Female NPT not Reusable
C = Female x Female NPT Not Reusable
D = Male x Male NPT Reusable
E = Male x Female NPT Reusable
F = Female x Female NPT Reusable
J = Male x Male BSP Reusable
K = Male x Female BSP Reusable
L = Female x Female BSP Reusable
S = Special (See Note 1)

FITTING BRAND - F

A = Internal Expansion Permanent (stainless steel only)
B = Dixon/UMI Internal Expansion (Permanent (Brass Insert))
D = Dixon Swaged
E = Dixon Reusable
F = Elaflex Resuable
G = Roman Seliger Reusable

INSERT MATERIAL - M

A = Brass
B = Stainless Steel
D = Tin-Plated Brass
F = Carbon Steel

OVERALL LENGTH - O

For all sizes except CP64, if "0" is present, LLLL = OAL
For CP64 only, if blank, LLLL = OAL
For CP64 only, if "C" present, LLLL = Cut Length

Available in these Sizes

Size	ID		NOM OD		MAX WP		WEIGHT	
	MM	IN	MM	PSI	MPA	LB/FT	KG/M	
3/4"	19	1.25	31.8	300	2.07	0.50	0.75	
1"	25	1.50	38.0	300	2.07	0.62	0.93	
1 1/4"	32	1.78	45.2	300	2.07	0.79	1.18	
1 1/2"	38	2.06	52.3	300	2.07	0.86	1.28	
2"	50	2.57	65.3	300	2.07	1.20	1.79	
2 1/2"	63	3.20	81.2	300	2.07	1.69	2.52	
3"	75	3.70	94.0	300	2.07	2.33	3.47	
4"	102	4.94	125.0	300	2.07	3.30	4.92	

Couplings

Permanent Brass	Internally expanded fittings (standard for 3/4" and 3" ID) - male NPT and female NPS (swivel nut)
Crimped on Stainless	Male NPT (zinc-plated ferrules) standard for 4" ID hose assemblies. Internally expanded brass male NPT and NPS are also available.
Reusable 4-Bolt	Aluminum clamp fittings - male and female, NPT and BSP threads - all females have swivel nuts - available with brass, tin-plated brass and stainless inserts.

Protective Coils

9746	2" Banding Coil, White
9744	3" Banding Coil, White
9774	4" Banding Coil, White



2325 Husky Way • Pacific, MO 63069
 (800) 325-3558 • Fax (636) 825-7300
www.husky.com • sales@husky.com

MADE IN THE U.S.A. 

4113 Reuseable



4113 with Reusable couplings aviation fueling hose recommended for all types of riser deck, reel, and hydrant hose applications.

- Used for commercial and private aircraft
- Resistant to jet fuel and higher aromatic aviation gasolines
- Compatible with use on hydrant service
- Meets EI 1529, 6th edition, 2005 and European Standard EN ISO 1825 (2011) and NPFA 407
- Recommended for all types of riser deck, reel, and hydrant hose applications
- All aviation hose assemblies are 100% hydrostatic tested to 600 PSI and inspected for electrical continuity
- Every hose receives a unique serial number and test certificate
- Standard hose assemblies are supplied with Roman Seliger brand 4-bolt aluminum clamp reusable couplings. Elaflex Spannloc are available on request.
- All 4" ID hoses utilize Roman Seliger 4-bolt aluminum clamped reusable fittings.

Specifying Information

MODEL NO.	DESCRIPTION	SHIPPING WEIGHT LBS (KG)
1 1/2" HOSES		
CP240720HKGB	1 1/2" X 60' 4113 MXF BSP SS RU	51.6 (23.5)
CP240792HEGA	1 1/2" X 66' 4113 MXF NPT BR RU	56.8 (25.8)
2" HOSES		
CP320720HKGB	2" x 60' 4113 MXF BSP SS RU	72.0 (32.7)
CP320720HKGA	2" x 60' 4113 MXF BSP BR RU	72.0 (32.7)
CP320792HEGA	2" x 66' 4113 MXF NPT BR RU	79.2 (36.0)
2 1/2" HOSES		
CP400120HEGD	2 1/2" x 10' 4113 MXF BSP TP RU	16.9 (7.7)
CP400144HEGD	2 1/2" x 12' 4113 MXF BSP TP RU	20.3 (9.2)
CP400156HDGB	2 1/2" x 13' 4113 MXM NPT SS RU	22.0 (10.0)
3" HOSES		
CP480144HEGD	3" x 12' 4113 MXF BSP TP RU	28.0 (12.7)
CP480168HABA	3" x 14' 4113 MXM NPT BR RU	32.6 (14.8)
CP480240HEGD	3" x 20' 4113 MXF BSP TP RU	46.6 (21.2)
CP480300HEGD	3" x 25' 4113 MXF BSP TP RU	58.3 (26.5)
CP480396HDGB	3" x 33' 4113 MXM NPT SS RU	76.9 (36.3)
CP480480HEGD	3" x 40' 4113 MXF BSP TP RU	93.2 (42.4)
4" HOSES		
CP640144HEGD	4" x 12' 4113 MXF BSP TP RU	39.6 (18.0)
CP640394HEGD	4" x 32.8' 4113 MXF BSP TP RU	108.2 (49.2)
CP640432HKGD	4" x 46' 4113 MXF BSP TP RU	151.8 (69.0)

Construction

Tube	Black nitrile synthetic rubber
Cover	Black neoprene static dissipating/static conductive synthetic rubber (wrapped finish)
Reinforcement	Spiral-plyed (4) synthetic fabric and one nylon breaker





4113 Reusable

4113 with Reusable couplings aviation fueling hose recommended for all types of riser deck, reel, and hydrant hose applications.

Available in these Sizes

ID	NOM OD		MAX WP		WEIGHT		
Size	MM	IN	MM	PSI	MPA	LB/FT	KG/M
3/4"	19	1.25	31.8	300	2.07	0.50	0.75
1"	25	1.50	38.0	300	2.07	0.62	0.93
1 1/4"	32	1.78	45.2	300	2.07	0.79	1.18
1 1/2"	38	2.06	52.3	300	2.07	0.86	1.28
2"	50	2.57	65.3	300	2.07	1.20	1.79
2 1/2"	63	3.20	81.2	300	2.07	1.69	2.52
3"	75	3.70	94.0	300	2.07	2.33	3.47
4"	102	4.94	125.0	300	2.07	3.30	4.92

Couplings

Permanent	Brass male and female NPT (swivel nut)
Reusable 4-bolt	Aluminum clamp fittings - male and female, NPT and BSP threads - all females have swivel nuts - available with brass, tin plated brass, and stainless inserts Aluminum male available for 2, 2 1/2 and 3-inch ID

Protective Coils

9746	2" Banding Coil, White
9744	3" Banding Coil, White
9774	4" Banding Coil, White
9793	3" Banding Coil, Orange

Order Guide (Ex. CP320600HABA)

AVIATION HOSE SIZE - CPSS

3/4" = CP12	2" = CP32
1" = CP16	2 1/2" = CP40
1 1/4" = CP20	3" = CP48
1 1/2" = CP24	4" = CP64

HOSE LENGTH (IN INCHES) - LLLL

0600 = 50 feet 0 inches
0606 = 50 feet 6 inches

AVIATION HOSE - H or J

H = 4113 Aviation Hose
J = 5500 JacRiser Hose

NOTE:

If special, the next two digits will be used sequentially first using numbers (0-9) then using Alpha (A-Z). Special fittings or special materials will be described in the fab/shipping instructions section of the factory order. See separate assembly drawing for each special assembly number.

FITTING STYLE - S

A = Male x Male NPT Not Reusable
B = Male x Female NPT not Reusable
C = Female x Female NPT Not Reusable
D = Male x Male NPT Reusable
E = Male x Female NPT Reusable
F = Female x Female NPT Reusable
J = Male x Male BSP Reusable
K = Male x Female BSP Reusable
L = Female x Female BSP Reusable
S = Special (See Note 1)

FITTING BRAND - F

A = Internal Expansion Permanent (stainless steel only)
B = Dixon/UMI Internal Expansion (Permanent (Brass Insert))
D = Dixon Swaged
E = Dixon Reusable
F = Elaflex Resuable
G = Roman Seliger Reusable

INSERT MATERIAL - M

A = Brass
B = Stainless Steel
D = Tin-Plated Brass
F = Carbon Steel

OVERALL LENGTH - O

For all sizes except CP64, if "0" is present, LLLL = OAL
For CP64 only, if blank, LLLL = OAL
For CP64 only, if "C" present, LLLL = Cut Length



2325 Husky Way • Pacific, MO 63069
(800) 325-3558 • Fax (636) 825-7300
www.husky.com • sales@husky.com

MADE IN THE U.S.A.

4113CT Permanent



4113CT Cold Temperature Hose Permanent Fitting aviation fueling hose recommended for all types of riser deck, reel, and hydrant hose applications.

- Used for commercial and private aircraft
- Resistant to jet fuel and higher aromatic aviation gasolines
- Compatible with use on hydrant service
- Meets EI 1529, 7th Edition, 2014 and European Standard EN ISO 1825 (2011), Type CT, Grade 2, NPFA 407 and MIL-DTL-6615G
- Operating temperature -67°F to +158°F (-55°C to +70°C)
- Recommended for all types of riser deck, reel, and hydrant hose applications
- All aviation hose assemblies are 100% hydrostatic tested to 600 PSI and inspected for electrical continuity
- Every hose receives a unique serial number and test certificate



Specifying Information

MODEL NO.	DESCRIPTION	SHIPPING WEIGHT LBS (KG)
1" HOSES		
CP160024CABA	1" x 2' HEW 4113CT MM NPT BR NR	1.24 (0.6)
CP160180CABA	1" x 15' HEW 4113CT MM NPT BR NR	10.0 (4.5)
CP160360CABA	1" x 30' HEW 4113CT MM NPT BR NR	20.0 (9.1)
CP160420CABA	1" x 35' HEW 4113CT MM NPT BR NR	23.0 (10.5)
CP160472CABA	1" x 39' 4" HEW 4113CT MM NPT BR NR	25.0 (11.3)
CP160480CABA	1" x 40' HEW 4113CT MM NPT BR NR	26.0 (11.8)
CP160588CABA	1" x 49' HEW 4113CT MM NPT BR NR	30.4 (13.8)
CP160600CABA	1" x 50' HEW 4113CT MM NPT BR NR	32.0 (14.5)
CP160720CABA	1" x 60' HEW 4113CT MM NPT BR NR	38.0 (17.3)
CP160792CABA	1" x 66' HEW 4113CT MM NPT BR NR	42.0 (19.1)
CP160900CABA	1" x 75' HEW 4113CT MM NPT BR NR	48.0 (21.8)
CP160960CABA	1" x 80' HEW 4113CT MM NPT BR NR	51.0 (23.1)
CP161080CABA	1" x 90' HEW 4113CT MM NPT BR NR	57.0 (25.9)
CP161200CABA	1" x 100' HEW 4113CT MM NPT BR NR	63.0 (28.6)
CP161380CABA	1" x 115' HEW 4113CT MM NPT BR NR	71.3 (32.4)
CP161560CABA	1" x 130' HEW 4113CT MM NPT BR NR	80.6 (36.6)
1 1/4" HOSES		
CP200600CABA	1 1/4" x 50' HEW 4113CT MM NPT BR NR	42.0 (19.1)
CP200660CABA	1 1/4" x 55' HEW 4113CT MM NPT BR NR	45.0 (20.1)
CP200792CABA	1 1/4" x 66' HEW 4113CT MM NPT BR NR	54.0 (24.5)
CP200840CBBA	1 1/4" x 70' HEW 4113CT MF NPT BR NR	57.0 (25.9)
CP200900CABA	1 1/4" x 75' HEW 4113CT MM NPT BR NR	61.0 (27.8)
CP201176CABA	1 1/4" x 98' HEW 4113CT MM NPT BR NR	77.4 (35.2)
CP201200CBBA	1 1/4" x 100' HEW 4113CT MF NPT BR NR	81.0 (36.8)
CP201200CABA	1 1/4" x 100' HEW 4113CT MM NPT BR NR	81.0 (36.8)
1 1/2" HOSES		
CP240024CABA	1 1/2" x 2' HEW 4113CT MM NPT BR NR	1.7 (0.8)
CP240108CABA	1 1/2" x 9' HEW 4113CT MM NPT BR NR	11.0 (5.0)
CP240120CABA	1 1/2" x 10' HEW 4113CT MM NPT BR NR	12.0 (5.5)
CP240600CABA	1 1/2" x 50' HEW 4113CT MM NPT BR NR	51.0 (23.2)
CP240720CABA	1 1/2" x 60' HEW 4113CT MM NPT BR NR	61.0 (27.8)
CP240780CBBA	1 1/2" x 65' HEW 4113CT MF NPT BR NR	66.0 (30.0)
CP240792CABA	1 1/2" x 66' HEW 4113CT MM NPT BR NR	67.0 (30.5)
CP240840CABA	1 1/2" x 70' HEW 4113CT MM NPT BR NR	71.0 (32.3)
CP240900CABA	1 1/2" x 75' HEW 4113CT MM NPT BR NR	76.0 (34.5)
CP241020CABA	1 1/2" x 85' HEW 4113CT MM NPT BR NR	85.0 (38.6)
CP241200CABA	1 1/2" x 100' HEW 4113CT MM NPT BR NR	100.0 (45.5)
CP241200CBBA	1 1/2" x 100' HEW 4113CT MF NPT BR NR	100.0 (45.5)

MODEL NO.	DESCRIPTION	SHIPPING WEIGHT LBS (KG)
CP240420CABA	1 1/2" x 35' HEW 4113CT MM NPT BR NR	36.0 (16.4)
CP240684CABA	1 1/2" x 57' HEW 4113CT MM NPT BR NR	49.0 (22.3)
CP240780CABA	1 1/2" x 65' HEW 4113CT MM NPT BR NR	66.0 (30.0)
CP241368CABA	1 1/2" x 114' HEW 4113CT MM NPT BR NR	98.0 (44.5)
CP241800CABA	1 1/2" x 150' HEW 4113CT MM NPT BR NR	129.0 (58.6)
2" HOSES		
CP320120CABA	2" x 10' HEW 4113CT MM NPT BR NR	16.0 (7.3)
CP320134CABA	2" x 11.17' HEW 4113CT MM NPT BR NR	13.4 (6.1)
CP320144CABA	2" x 12' HEW 4113CT MM NPT BR NR	19.0 (8.6)
CP320180CABA	2" x 15' HEW 4113CT MM NPT BR NR	23.0 (10.5)
CP320197CABA	2" x 16' 5" HEW 4113CT MM NPT BR NR	24.0 (10.9)
CP320216CABA	2" x 18' HEW 4113CT MM NPT BR NR	26.0 (11.8)
CP320240CABA	2" x 20' HEW 4113CT MM NPT BR NR	29.0 (13.2)
CP320420CABA	2" x 35' HEW 4113CT MM NPT BR NR	49.0 (22.3)
CP320480CABA	2" x 40' HEW 4113CT MM NPT BR NR	55.0 (25.0)
CP320564CABA	2" x 47' HEW 4113CT MM NPT BR NR	56.4 (25.6)
CP320600CABA	2" x 50' HEW 4113CT MM NPT BR NR	68.0 (30.9)
CP320600CBBA	2" x 50' HEW 4113CT MF NPT BR NR	68.0 (30.9)
CP320684CABA	2" x 57' HEW 4113CT MM NPT BR NR	68.4 (31.1)
CP320720CABA	2" x 60' HEW 4113CT MM NPT BR NR	81.0 (36.8)
CP320792CABA	2" x 66' HEW 4113CT MM NPT BR NR	89.0 (40.5)
CP320900CABA	2" x 75' HEW 4113CT MM NPT BR NR	101.0 (45.9)
2 1/2" HOSES		
CP400096CABA	2 1/2" x 8' HEW 4113CT MM NPT BR NR	19.0 (8.6)
CP400108CABA	2 1/2" x 9' HEW 4113CT MM NPT BR NR	20.0 (9.1)
CP400120CBBA	2 1/2" x 10' HEW 4113CT MF NPT BR NR	22.0 (10.0)
CP400120CABA	2 1/2" x 10' HEW 4113CT MM NPT BR NR	22.0 (10.0)
CP400144CABA	2 1/2" x 12' HEW 4113CT MM NPT BR NR	25.0 (11.4)
CP400156CABA	2 1/2" x 13' HEW 4113CT MM NPT BR NR	27.0 (12.3)
CP400192CABA	2 1/2" x 16' HEW 4113CT MM NPT BR NR	32.0 (14.5)
CP400197CABA	2 1/2" x 16' 5" HEW 4113CT MM NPT BR NR	33.0 (15.0)
CP400420CABA	2 1/2" x 35' HEW 4113CT MM NPT BR NR	64.0 (29.1)
CP400480CABA	2 1/2" x 40' HEW 4113CT MM NPT BR NR	73.0 (33.2)
CP400600CBBA	2 1/2" x 50' HEW 4113CT MF NPT BR NR	90.0 (40.9)
CP400600CABA	2 1/2" x 50' HEW 4113CT MM NPT BR NR	90.0 (40.9)
CP400660CABA	2 1/2" x 55' HEW 4113CT MM NPT BR NR	98.0 (44.5)
CP400720CABA	2 1/2" x 60' HEW 4113CT MM NPT BR NR	106.0 (48.2)
CP400084CABA	2 1/2" x 7' HEW 4113CT MM NPT BR NR	17.0 (7.7)
CP400118CABA	2 1/2" x 9' 3" HEW 4113CT MM NPT BR NR	20.0 (9.1)



WARNING: Cancer and Reproductive Harm - www.P65Warnings.ca.gov



4113CT Permanent

4113CT Cold Temperature Hose Permanent Fitting aviation fueling hose recommended for all types of riser deck, reel, and hydrant hose applications.

MODEL NO.	DESCRIPTION	SHIPPING WEIGHT LBS (KG)
CP400132CABA	2 ¹ / ₂ " x 11' HEW 4113CT MM NPT BR NR	34.0 (15.5)
CP400180CABA	2 ¹ / ₂ " x 15' HEW 4113CT MM NPT BR NR	30.0 (13.6)
CP400240CABA	2 ¹ / ₂ " x 20' HEW 4113CT MM NPT BR NR	39.0 (17.7)
CP400684CABA	2 ¹ / ₂ " x 57' HEW 4113CT MM NPT BR NR	100.0 (45.5)
CP401200CBBA	2 ¹ / ₂ " x 100' HEW 4113CT MF NPT BR NR	174.0 (79.1)
3" HOSES		
CP480096CABA	3" x 8' HEW 4113CT MM NPT BR NR	28.0 (12.7)
CP480108CABA	3" x 9' HEW 4113CT MM NPT BR NR	31.0 (14.1)
CP480120CABA	3" x 10' HEW 4113CT MM NPT BR NR	34.0 (15.5)
CP480132CABA	3" x 11' HEW 4113CT MM NPT BR NR	36.0 (16.4)
CP480144CABA	3" x 12' HEW 4113CT MM NPT BR NR	39.0 (17.7)
CP480168CABA	3" x 14' HEW 4113CT MM NPT BR NR	44.0 (20.0)
CP480180CABA	3" x 15' HEW 4113CT MM NPT BR NR	46.0 (20.9)
CP480240CABA	3" x 20' HEW 4113CT MM NPT BR NR	59.0 (26.8)
CP480360CBBA	3" x 30' HEW 4113CT MF NPT BR NR	85.0 (38.6)
CP480600CBBA	3" x 50 FT HEW 4113CT MF NPT BR NR	136.0 (61.8)
CP480600CABA	3" x 50' HEW 4113CT MM NPT BR NR	136.0 (61.8)
CP480720CABA	3" x 60' HEW 4113CT MM NPT BR NR	162.0 (73.6)

Construction

Tube	Black nitrile synthetic rubber
Cover	Black neoprene static dissipating/static conductive synthetic rubber (wrapped finish)
Reinforcement	Spiral-plyed (4) synthetic fabric and one nylon breaker
Couplings	Permanent brass internally expanded fittings - male and female NPT (swivel nut) Reusable 4-bolt aluminum clamp fittings - male and female, NPT and BSP threads - all females have swivel nuts - available with brass, tin plated brass, and stainless inserts

Technical Data for 4113CT Cold Temperature Fueling Hose

Size	ID		NOM OD		MAX WP		WEIGHT	
	MM	IN	MM	PSI	MPA	LB/FT	KG/M	
1"	25	1.457	37	300	2.07	0.54	0.80	
1 ¹ / ₄ "	32	1.732	44	300	2.07	0.67	1.00	
1 ¹ / ₂ "	38	2.008	51	300	2.07	0.81	1.20	
2"	50	2.598	66	300	2.07	1.28	1.90	
2 ¹ / ₂ "	63	3.110	79	300	2.07	1.61	2.40	
3"	75	3.583	91	300	2.07	1.88	2.80	

Couplings

Permanent Brass	Internally expanded fittings (standard for 1" and 3" ID) - male NPT and female NPS (swivel nut)
Crimped on Stainless	Male NPT (zinc-plated ferrules) standard for 4" ID hose assemblies. Internally expanded brass male NPT and NPS are also available.
Reusable 4-Bolt	Aluminum clamp fittings - male and female, NPT and BSP threads - all females have swivel nuts - available with brass, tin-plated brass and stainless inserts.

Protective Coils

9746	2" Banding Coil, White
9744	3" Banding Coil, White
9774	4" Banding Coil, White

Order Guide (Ex. CP320600CABA)

AVIATION HOSE SIZE - CPSS

3/4" = CP12	2" = CP32
1" = CP16	2 ¹ / ₂ " = CP40
1 ¹ / ₄ " = CP20	3" = CP48
1 ¹ / ₂ " = CP24	4" = CP64

HOSE LENGTH (IN INCHES) - LLLL

0600 = 50 feet 0 inches
0606 = 50 feet 6 inches

AVIATION HOSE - H, C OR J

H = 4113 Aviation Hose
C = 4113CT Cold Temp
J = 5500 JacRiser Hose

NOTE:

If special, the next two digits will be used sequentially first using numbers (0-9) then using Alpha (A-Z). Special fittings or special materials will be described in the fab/shipping instructions section of the factory order. See separate assembly drawing for each special assembly number.

FITTING STYLE - S

A = Male x Male NPT Not Reusable
B = Male x Female NPT not Reusable
C = Female x Female NPT Not Reusable
D = Male x Male NPT Reusable
E = Male x Female NPT Reusable
F = Female x Female NPT Reusable
J = Male x Male BSP Reusable
K = Male x Female BSP Reusable
L = Female x Female BSP Reusable
S = Special (See Note 1)

FITTING BRAND - F

A = Internal Expansion Permanent (stainless steel only)
B = Dixon/UMI Internal Expansion (Permanent (Brass Insert))
D = Dixon Swaged
E = Dixon Reusable
F = Elaflex Resuable
G = Roman Seliger Reusable

INSERT MATERIAL - M

A = Brass
B = Stainless Steel
D = Tin-Plated Brass
F = Carbon Steel

OVERALL LENGTH - O

For all sizes except CP64, if "0" is present, LLLL = OAL
For CP64 only, if blank, LLLL = OAL
For CP64 only, if "C" present, LLLL = Cut Length



2325 Husky Way • Pacific, MO 63069
(800) 325-3558 • Fax (636) 825-7300
www.husky.com • sales@husky.com

MADE IN THE U.S.A.



JacRiser Fueling Hoses



5500 JacRiser



Used in riser connection of aviation refuelers, hydrant cart servicers and tank farm connections.

- Used for commercial and private aircraft.
- Resistant to jet fuel and higher aromatic aviation gasolines.
- Premium fueling and defueling hose designed to achieve more than twice the cycle flexing capabilities (124000 plus cycles).
- Meets both EI 1529, 7th edition, and European standard EN ISO 1825 Type E, Plus NFPA 407.
- Suitable for full vacuum service and high flex applications.
- Designed for flexible connection between hydrant cart or refueler chassis and adjustable riser platform.
- Functional in temperatures -40°F to 180°F (-40°C to 82°C).
- All aviation hose assemblies are 100% hydrostatic tested to 600 PSI and inspected for electrical continuity.
- Every hose receives a unique serial number and test certificate.

Swaged on Stainless Male NPT - 4 Inch ID Hoses

MODEL NO.	DESCRIPTION	SHIPPING WEIGHT LBS (KG)
CP640092JADB	4" x 92" OAL JAC 5500 MXM NPT SS NR	51 (23.2)
CP640102JADB	4" x 102" OAL JAC 5500 MXM NPT SS NR	55 (25.0)
CP640132JADB	4" x 11' OAL JAC 5500 MXM NPT SS NR	66 (30.0)
CP640108JADB	4" x 9' OAL JAC 5500 MXM NPT SS NR	57 (25.9)
CP640420JADB	4" x 35' OAL JAC 5500 MXM NPT SS NR	171 (77.7)
CP640087JADB	4" x 87" OAL JAC 5500 MXM NPT SS NR	50 (22.7)
CP640128JADB	4" x 128" OAL JAC 5500 MXM NPT SS NR	65 (29.5)
CP640126JADB	4" x 10'6" OAL JAC 5500 MXM NPT SS NR	64 (29.1)
CP640110JADB	4" x 110" OAL JAC 5500 MXM NPT SS NR	54 (24.5)

Internally Expanded Brass Male NPT - 1-1/2, 2, 2-1/2 and 3 Inch ID Hoses

MODEL NO.	DESCRIPTION	SHIPPING WEIGHT LBS (KG)
CP240480JABA	1-1/2" X 40' 5500 MXM NPT BR NR	54 (24.5)
CP240400JABA	1-1/2" X 70' 5500 MXM NPT BR NR	94 (42.6)
CP320480JABA	2" x 40' JAC 5500 MXM NPT BR NR	67 (30.4)
CP320900JABA	2" x 75' JAC 5500 MXM NPT BR NR	123 (55.8)
CP400120JABA	2-1/2" X 10' 5500 MXM NPT BR NR	25 (11.3)
CP400360JABA	2-1/2" X 30' 5500 MXM NPT BR NR	69 (31.3)
CP480180JABA	3" x 15' JAC 5500 MXM NPT BR NR	53 (24.0)
CP480300JABA	3" x 25' JAC 5500 MXM NPT BR NR	83 (37.6)
CP480144JABA	3" x 12' JAC 5500 MXM NPT BR NR	44 (20.0)
CP480096JABA	3" x 8' JAC 5500 MXM NPT BR NR	32 (14.5)

Construction

Tube	Black nitrile synthetic rubber
Cover	Black neoprene static dissipating/static conductive synthetic rubber (wrapped finish)
Reinforcement	Spiral-plied (4) synthetic fabric and one nylon breaker with dual wire helix construction



Above are examples of existing part numbers. Husky can build any hose to any length with a variety of fittings. Contact Husky for additional information if you do not see an assembly that matches your needs.

Used in riser connection of aviation refuelers, hydrant cart servicers and tank farm connections.

Dimensions and System Options

Available in these Sizes

ID	NOM OD		MAX WP		BEND RADIUS		WEIGHT		
Size	MM	IN	MM	PSI	MPA	IN	MM	LB/FT	KG/M
1-1/2"	38	2.18	55.4	300	2.07	6.0	152	1.27	1.89
2"	50	2.756	69.8	300	2.07	8.0	203	1.74	2.59
2-1/2"	63.5	3.22	81.9	300	2.07	10.0	254	2.13	3.17
3"	75	3.82	98.6	300	2.07	12.0	305	2.93	4.36
4"	102	4.97	126.2	300	2.07	16.0	406	4.40	6.55

Couplings

Permanent Brass	Internally expanded fittings (standard for 2" and 3" ID) - male NPT and female NPS (swivel nut)
Swaged on Stainless	Male NPT (zinc-plated ferrules) standard for 4" ID hose assemblies. Internally expanded brass male NPT and NPS are also available.
Reusable 4-Bolt	Aluminum clamp fittings - male and female, NPT and BSP threads - all females have swivel nuts - available with brass, tin-plated brass and stainless inserts.

Protective Coils

9746	2" Banding Coil, White
9744	3" Banding Coil, White
9774	4" Banding Coil, White
9793	3" Banding Coil, Orange



Order Guide (Ex. CP320600JABA)

AVIATION HOSE SIZE - CPSS

3/4" = CP12	2" = CP32
1" = CP16	2 1/2" = CP40
1 1/4" = CP20	3" = CP48
1 1/2" = CP24	4" = CP64

HOSE LENGTH (IN INCHES) - LLLL

0600 = 50 feet 0 inches
0606 = 50 feet 6 inches

AVIATION HOSE - H or J

H = 4113 Aviation Hose
J = 5500 JacRiser Hose

NOTE:

If special, the next two digits will be used sequentially first using numbers (0-9) then using Alpha (A-Z). Special fittings or special materials will be described in the fab/shipping instructions section of the factory order. See separate assembly drawing for each special assembly number.

FITTING STYLE - S

A = Male x Male NPT Not Reusable
B = Male x Female NPT not Reusable
C = Female x Female NPT Not Reusable
D = Male x Male NPT Reusable
E = Male x Female NPT Reusable
F = Female x Female NPT Reusable
J = Male x Male BSP Reusable
K = Male x Female BSP Reusable
L = Female x Female BSP Reusable
S = Special (See Note 1)

FITTING BRAND - F

A = Internal Expansion Permanent (stainless steel only)
B = Dixon/UMI Internal Expansion (Permanent (Brass Insert))
D = Dixon Swaged
E = Dixon Reusable
F = Elaflex Resuable
G = Roman Seliger Reusable

INSERT MATERIAL - M

A = Brass
B = Stainless Steel
D = Tin-Plated Brass
F = Carbon Steel

OVERALL LENGTH - O

For all sizes except CP64, if "0" is present, LLLL = OAL
For CP64 only, if blank, LLLL = OAL
For CP64 only, if "C" present, LLLL = Cut Length



2325 Husky Way • Pacific, MO 63069
 (800) 325-3558 • Fax (636) 825-7300
www.husky.com • sales@husky.com

MADE IN THE U.S.A. 



AVIATION FUELING PRODUCTS

Couplings



Aviation Couplings



In order to meet and comply with EI 1529 and EN ISO 1825 specifications, all Hewitt® aviation hoses are supplied with either permanent or reusable couplings.

Permanent Couplings

- Internally expanded brass and stainless fittings. Stainless available upon request.
- NPT male and NPSH female threads (swivel nuts on female fittings)
- Swaged stainless male NPT insert with zinc-plated ferrule (Standard on 4" only).
- 4" internally expanded brass male NPT and NPSH female inserts are available as options.

Reusable Couplings

- 4-bolt aluminum clamps with brass, tin-plated brass or stainless inserts
- NPT male, NPSH female, BSP male and BSP female threads (swivel nuts on female fittings)
- Reusable fittings are available as separate items on request.

Adaptors

- Any of the above fittings can be supplied with adaptors such as Cam & Groove and threaded flanges.
- Dixon "Boss" Cam & Groove fittings are USA made. Imported versions are available.
- Stainless, brass, and aluminum step-up bushings.
- Stainless, carbon steel and aluminum threaded flanges.





Aviation Couplings



2325 Husky Way • Pacific, MO 63069
(800) 325-3558 • Fax (636) 825-7300
www.husky.com • sales@husky.com

MADE IN THE U.S.A. 



AVIATION FUELING PRODUCTS

Protective Coils



Spiral Hose Protectors



Hewitt

AVIATION FUELING PRODUCTS

Used to extend hose life, prevent kinking and reduce abrasion.

- Excellent for extending hose life, preventing kinking on deck and reel hoses, and reducing abrasion to hose cover.
- Installing coils at hose reel outlet riser will prevent hose collapse and maintain high fuel flow.
- Covers from 2 to 4 feet.
- Available to fit 1" to 4" ID aviation hose.
- Easily installed by factory or in the field.
- Standard white hose coils available from stock.
- Special colors and extra tough urethane hose protector coil available upon request.

Specifying Information

MODEL NO.	DESCRIPTION	SHIPPING WEIGHT FT/LBS.
9746	2" Banding Coil, White	0.6385
9744	3" Banding Coil, White	1.2260
9774	4" Banding Coil, White	1.5710
9793	3" Banding Coil, Orange	1.2260

Construction

Material	PVC
----------	-----



**Hewitt**

AVIATION FUELING PRODUCTS

Spiral Hose Protectors

PROTECTIVE COILS



2325 Husky Way • Pacific, MO 63069
(800) 325-3558 • Fax (636) 825-7300
www.husky.com • sales@husky.com

MADE IN THE U.S.A.





AVIATION FUELING PRODUCTS

Deadman Hoses



Twin 1/4-Inch



Used in connection of deadman control during aircraft servicing.

- Integral assembly for use with the deadman control valve.
- Vertically braided textile.
- Twinned 1/4" diameter red and green hose is vulcanized.
- Highly resistant to oil.
- Available in bulk or with crimped-on male or female swivel fittings.

Specifying Information

MODEL NO.	DESCRIPTION	SHIPPING WEIGHT LBS. (KG)
9742	Hose, A, 1/4" Deadman Tinline	0.20 (0.09)

Spring Guards

MODEL NO.	DESCRIPTION	SHIPPING WEIGHT LBS.
9878	1/4" x 50' Dead MXF with spring guard	11.25

Construction

Tube	Nitrile synthetic rubber, RMA Class A
Color	One red hose, one green hose



Used in connection of deadman control during aircraft servicing.

Dimensions and System Options

Available in these Sizes

ID (IN)	ID (MM)	SPIRALS	OD (IN)	OD (MM)	LB/FT	KG/M
1/4	6.4	2	34/64	13.5	0.19	0.28

Fittings

Crimped on male or female swivels.

Options

Available in cut lengths assembled or in bulk (approx. 700 ft. per reel).

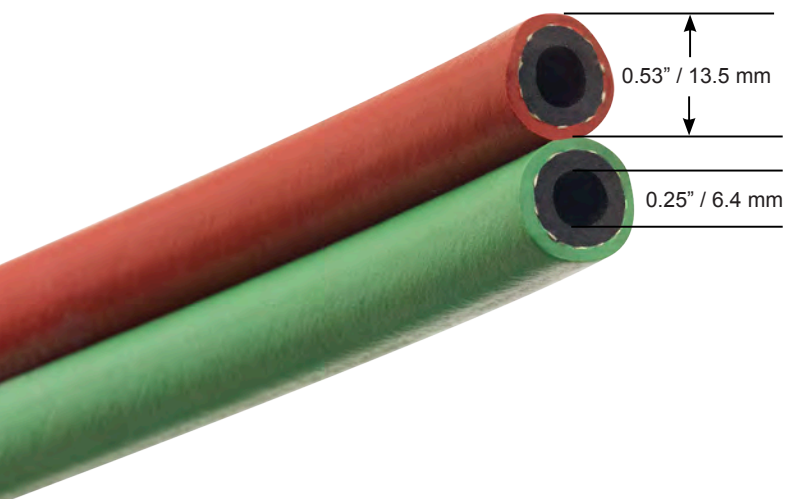

2325 Husky Way • Pacific, MO 63069
 (800) 325-3558 • Fax (636) 825-7300
www.husky.com • sales@husky.com

MADE IN THE U.S.A. 



AVIATION FUELING PRODUCTS

Sensing Hoses



Twin $\frac{3}{8}$ -Inch



Used in connection of aircraft servicers and airport hydrants and sensing control systems.

- Integral assembly to connect aircraft servicers to airport hydrant reference and sensing control systems.
- Vertically braided textile.
- Twinned $\frac{3}{8}$ " diameter yellow and green hose is vulcanized.
- Highly resistant to oil.
- Available in bulk or with crimped-on male or female swivel fittings.

Specifying Information

MODEL NO.	DESCRIPTION	SHIPPING WEIGHT LBS. (KG)
9743	Hose, A, $\frac{3}{8}$ " Sensing Hose Twinline	0.29 (0.13)

Construction

Tube	Nitrile synthetic rubber, RMA Class A
Color	One yellow, one green hose



Used in connection of aircraft servicers and airport hydrants and sensing control systems.

Dimensions and System Options

Available in these Sizes

ID (IN)	ID (MM)	SPIRALS	OD (IN)	OD (MM)	LB/FT	KG/M
³ / ₈	9.5	2	21/32	16.6	0.29	0.43

Fittings

Crimped on male or female swivels.

Options

Available in cut lengths assembled or in bulk (approx. 700 ft. per reel).

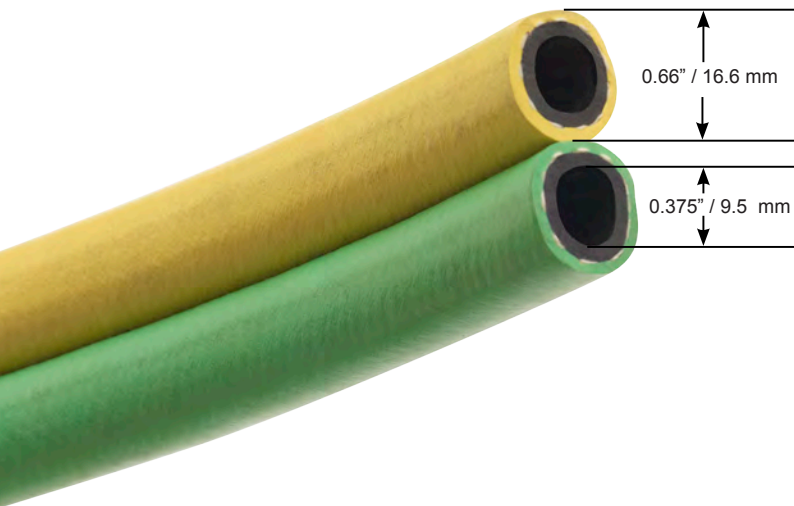

2325 Husky Way • Pacific, MO 63069
 (800) 325-3558 • Fax (636) 825-7300
www.husky.com • sales@husky.com

MADE IN THE U.S.A. 



Aviation Fueling Nozzles

Osprey Nozzle



Automatic shut-off nozzle for over-the-wing fueling of aircraft.

- Specifically designed for business and private over-the-wing aviation fueling.
- Automatic shut-off when wing tanks are full.
- Easy to remove and clean fuel 100 mesh SS fuel filter assembly.
- Nozzle comes with red full grip guard to identify use only with aviation fuel or black full grip guard for jet fuel application if desired.
- Complies with IE1540 and NPA 407.



Osprey Nozzle with NPT

MODEL NO.	DESCRIPTION	SHIPPING WEIGHT LBS. (KG)
1149812N [^]	without Hold Open Clip and Spout Bushing, with Waffle Splash Guard and mesh filter	4.6 (2.0)
		[^] NOT LISTED

Osprey Nozzle with BSPP

MODEL NO.	DESCRIPTION	SHIPPING WEIGHT LBS. (KG)
1149840N [^]	without Hold Open Clip and Spout Bushing, with Waffle Splash Guard and mesh filter	4.6 (2.0)
		[^] NOT LISTED

Construction

Body	Aluminum
Seals	Fluorocarbon
Packing	Double o-ring seal protected by fiber reinforced Teflon [®]
Lever	One piece contoured steel
Inlet	1" / 25.4 mm NPT and BSPP

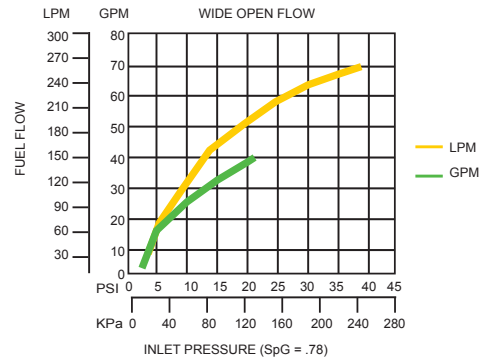

Automatic shut-off nozzle for over-the-wing fueling of aircraft.

Dimensions and System Options

Swivels

MODEL NO.	DESCRIPTION
008517	1" M x 1" F NPT Single Plane Swivel
004860	1" M x 1" F NPT Multi-Plane High Flow Swivel
003306	1" M x 1" F BSPP Multi-Plane Swivel
006949	1" M x 1" F BSPP Multi-Plane High Flow Swivel

Accessories

MODEL NO.	DESCRIPTION
011817	Electrical Grounding Plug
012141	Osprey Spout Assembly Kit
011946	Spout Cap Assembly
012148	Strainer BSP Kit
012143	Strainer NPT Kit

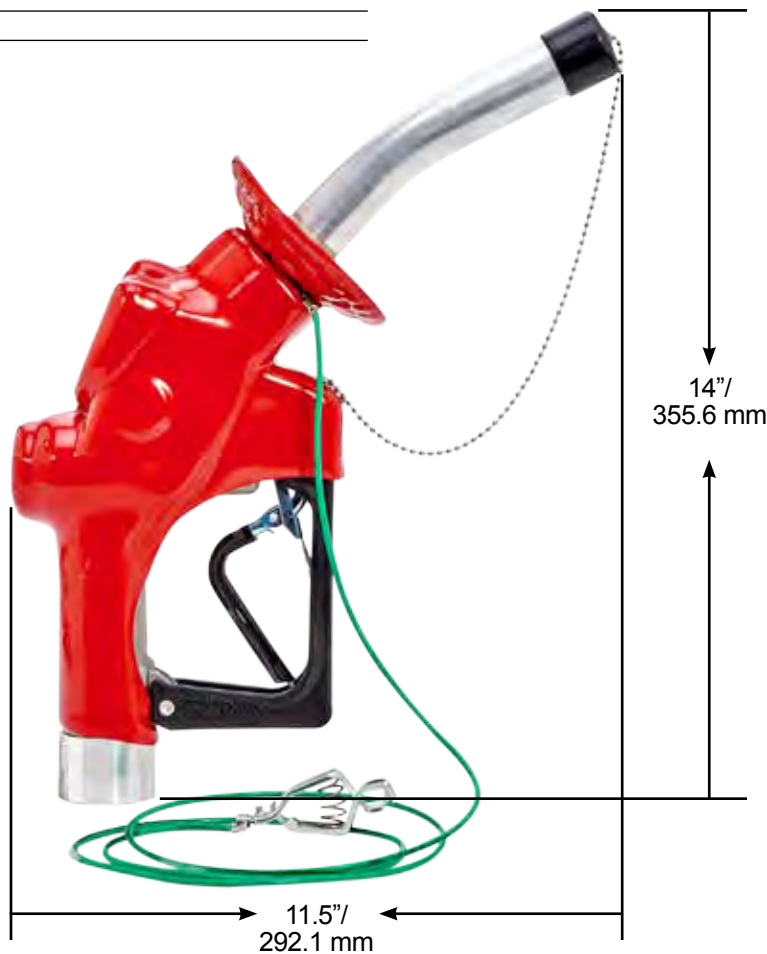

2325 Husky Way • Pacific, MO 63069
 (800) 325-3558 • Fax (636) 825-7300
www.husky.com • sales@husky.com

MADE IN THE U.S.A. 

Osprey S Nozzle



Automatic shut-off nozzle for over-the-wing fueling of aircraft.

- Specifically designed for business and private over-the-wing aviation fueling.
- Osprey S nozzle prevents draining of fuel from fueling hose. The nozzle shuts off when
 - the pump shuts off.
 - the fuel tank is full.
 - the lever is opened before the pump is turned on.
- Easy to remove and clean 100 mesh SS fuel filter assembly.
- Nozzle comes with red full grip guard to identify use only with AvGas or black full grip guard for jet fuel application if desired.
- Complies with IE1540 and NPA 407.

Osprey S Nozzle with NPT

MODEL NO.	DESCRIPTION	SHIPPING WEIGHT LBS. (KG)
1212312N [^]	without Hold Open Clip and Spout Bushing, with Waffle Splash Guard and mesh filter	4.6 (2.0)
		[^] NOT LISTED

Osprey S Nozzle with BSPP

MODEL NO.	DESCRIPTION	SHIPPING WEIGHT LBS. (KG)
1212340N [^]	without Hold Open Clip and Spout Bushing, with Waffle Splash Guard and mesh filter	4.6 (2.0)
		[^] NOT LISTED

Construction

Body	Aluminum
Seals	Fluorocarbon
Packing	Double o-ring seal protected by fiber reinforced Teflon [®]
Lever	One piece contoured steel
Inlet	1" / 25.4 mm NPT and BSPP

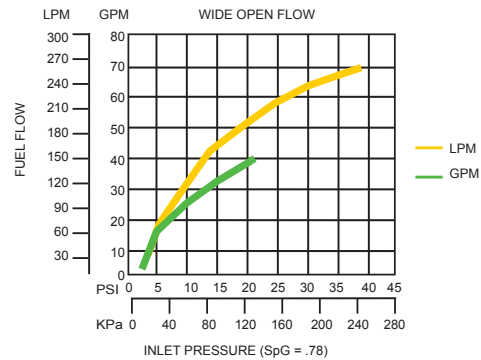

Automatic shut-off nozzle for over-the-wing fueling of aircraft.

Dimensions and System Options

Swivels

MODEL NO.	DESCRIPTION
008517	1" M x 1" F NPT Single Plane Swivel
004860	1" M x 1" F NPT Multi-Plane High Flow Swivel
003306	1" M x 1" F BSPP Multi-Plane Swivel
006949	1" M x 1" F BSPP Multi-Plane High Flow Swivel

Accessories

MODEL NO.	DESCRIPTION
011817	Electrical Grounding Plug
012139	Osprey S Spout Assembly Kit
011946	Spout Cap Assembly
012148	Strainer BSP Kit
012143	Strainer NPT Kit

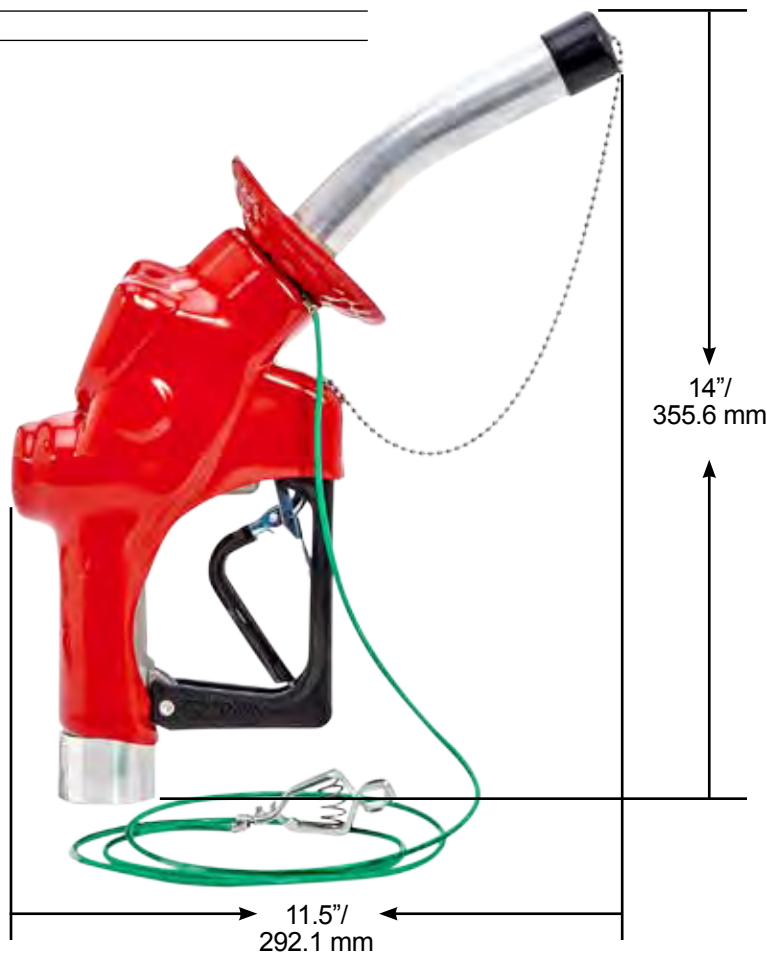

2325 Husky Way • Pacific, MO 63069
 (800) 325-3558 • Fax (636) 825-7300
www.husky.com • sales@husky.com

MADE IN THE U.S.A. 

Falcon Manual Nozzle



Manual shut-off nozzle for over-the-wing fueling of aircraft.

- Specifically designed for business and private over-the-wing aviation fueling.
- Spout can be removed by loosening nut.
- 100 mesh stainless steel fuel filter to prevent dust and debris from entering the fuel tank; located in the spout for easy removal and cleaning.
- Complies with IE 1540 and NPA 407.
- Black jet fuel nozzle with optional duck bill spout or round spout.
- Red aviation gas nozzle with round spout.
- Available with the following inlets:
 1-1/2" (38mm) Female NPT
 1-1/2" (38mm) Female BSPP
 1-1/4" (32mm) Female NPT
 1-1/4" (32mm) Female BSPP



Falcon Nozzle with NPT

MODEL NO.	DESCRIPTION	SHIPPING WEIGHT LBS. (KG)
12090218N [^]	without Hold Open Clip, with Jet Black, Duck Bill Spout, and 1½ FNPT (38mm) Inlet Inline Swivel	5.0 (2.3)
12090219N [^]	without Hold Open Clip, with Jet Black, Duck Bill Spout, and 1¼ FNPT (32mm) Inlet Inline Swivel	5.0 (2.3)
13734218N [^]	without Hold Open Clip, with Jet Black, Round Spout, and 1½ FNPT (38mm) Inlet Inline Swivel	5.0 (2.3)
13734219N [^]	without Hold Open Clip, with Jet Black, Round Spout, and 1¼ FNPT (32mm) Inlet Inline Swivel	5.0 (2.3)
13739218N [^]	without Hold Open Clip, with Aviation Red, Round Spout, and 1½ FNPT (38mm) Inlet Inline Swivel	5.0 (2.3)
13739219N [^]	without Hold Open Clip, with Aviation Red, Round Spout, and 1¼ FNPT (32mm) Inlet Inline Swivel	5.0 (2.3)

[^] NOT LISTED

Falcon Nozzle with BSPP

MODEL NO.	DESCRIPTION	SHIPPING WEIGHT LBS. (KG)
12090216N [^]	without Hold Open Clip, with Jet Black, Duck Bill Spout, and 1½ FBSP (38mm) Inlet Inline Swivel	5.0 (2.3)
12090217N [^]	without Hold Open Clip, with Jet Black, Duck Bill Spout, and 1¼ FBSP (32mm) Inlet Inline Swivel	5.0 (2.3)
13734216N [^]	without Hold Open Clip, with Jet Black, Round Spout, and 1½ FBSP (38mm) Inlet Inline Swivel	5.0 (2.3)
13734217N [^]	without Hold Open Clip, with Jet Black, Round Spout, and 1¼ FBSP (32mm) Inlet Inline Swivel	5.0 (2.3)
13739216N [^]	without Hold Open Clip, with Aviation Red, Round Spout, and 1½ FBSP (38mm) Inlet Inline Swivel	5.0 (2.3)
13739217N [^]	without Hold Open Clip, with Aviation Red, Round Spout, and 1¼ FBSP (32mm) Inlet Inline Swivel	5.0 (2.3)

[^] NOT LISTED

Construction

Body	Aluminum
Seals	Fluorocarbon
Packing	Double o-ring seal protected by fiber reinforced Teflon®
Lever	One piece contoured steel

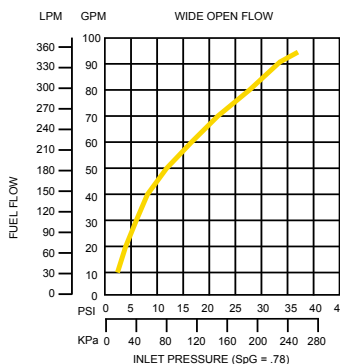

Manual shut-off nozzle for over-the-wing fueling of aircraft.

Dimensions and System Options

Accessories

MODEL NO.	DESCRIPTION
012946	Jet Oval Manual Spout Kit
012948	Aviation Round Manual Spout Kit
013476	Interlock Hook Assembly
014204	Black Jet Fuel Oval Spout Cap Assembly
014205	Black Jet Fuel Round Spout Cap Assembly
014206	Red Aviation Fuel Round Spout Cap Assembly

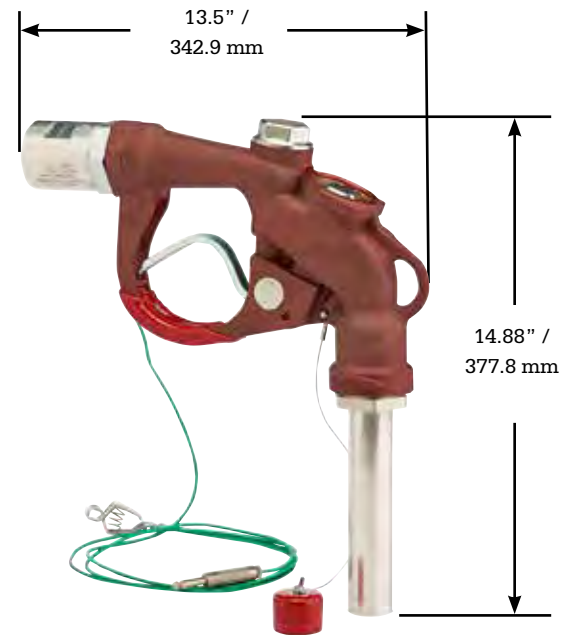

2325 Husky Way • Pacific, MO 63069
 (800) 325-3558 • Fax (636) 825-7300
www.husky.com • sales@husky.com

MADE IN THE U.S.A. 

Falcon Manual Quick Disconnect Nozzle



Manual shut-off nozzle for over-the-wing fueling of aircraft.

- Specifically designed for business and private over-the-wing aviation fueling.
- Quick disconnect spout feature for easy removal.
- 100 mesh stainless steel fuel filter to prevent dust and debris from entering the fuel tank; located in the spout for easy removal and cleaning.
- Complies with IE 1540 and NPA 407.
- Black jet fuel nozzle with optional duck bill spout or round spout.
- Red aviation gas nozzle with round spout.
- Available with the following inlets:
 1-1/2" (38mm) Female NPT
 1-1/2" (38mm) Female BSPP
 1-1/4" (32mm) Female NPT
 1-1/4" (32mm) Female BSPP



Falcon Nozzle with NPT

MODEL NO.	DESCRIPTION	SHIPPING WEIGHT LBS. (KG)
13731218N [^]	without Hold Open Clip, with Jet Black, Duck Bill Spout, and 1½ FNPT (38mm) Inlet Inline Swivel	5.0 (2.3)
13731219N [^]	without Hold Open Clip, with Jet Black, Duck Bill Spout, and 1¼ FNPT (32mm) Inlet Inline Swivel	5.0 (2.3)
13736218N [^]	without Hold Open Clip, with Jet Black, Round Spout, and 1½ FNPT (38mm) Inlet Inline Swivel	5.0 (2.3)
13736219N [^]	without Hold Open Clip, with Jet Black, Round Spout, and 1¼ FNPT (32 mm) Inlet Inline Swivel	5.0 (2.3)
13742218N [^]	without Hold Open Clip, with Aviation Red, Round Spout, and 1½ FNPT (38mm) Inlet Inline Swivel	5.0 (2.3)
13742219N [^]	without Hold Open Clip, with Aviation Red, Round Spout, and 1¼ FNPT (32mm) Inlet Inline Swivel	5.0 (2.3)

[^] NOT LISTED

Falcon Nozzle with BSPP

MODEL NO.	DESCRIPTION	SHIPPING WEIGHT LBS. (KG)
13731216N [^]	without Hold Open Clip, with Jet Black, Duck Bill Spout, and 1½ FBSP (38mm) Inlet Inline Swivel	5.0 (2.3)
13731217N [^]	without Hold Open Clip, with Jet Black, Duck Bill Spout, and 1¼ FBSP (32mm) Inlet Inline Swivel	5.0 (2.3)
13736216N [^]	without Hold Open Clip, with Jet Black, Round Spout, and 1½ FBSP (38mm) Inlet Inline Swivel	5.0 (2.3)
13736217N [^]	without Hold Open Clip, with Jet Black, Round Spout, and 1¼ FBSP (32mm) Inlet Inline Swivel	5.0 (2.3)
13742216N [^]	without Hold Open Clip, with Aviation Red, Round Spout, and 1½ FBSP (38mm) Inlet Inline Swivel	5.0 (2.3)
13742217N [^]	without Hold Open Clip, with Aviation Red, Round Spout, and 1¼ FBSP (32mm) Inlet Inline Swivel	5.0 (2.3)

[^] NOT LISTED

Construction

Body	Aluminum
Seals	Fluorocarbon
Packing	Double o-ring seal protected by fiber reinforced Teflon®
Lever	One piece contoured steel

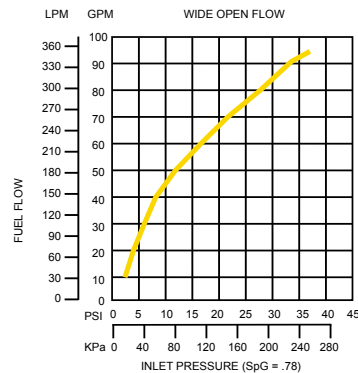

Manual shut-off nozzle for over-the-wing fueling of aircraft.

Dimensions and System Options

Accessories

MODEL NO.	DESCRIPTION
012947	Jet Oval Quick Disconnect Manual Spout Kit
012949	Aviation Quick Disconnect Round Manual Spout Kit
013476	Interlock Hook Assembly
014204	Black Jet Fuel Oval Spout Cap Assembly
014205	Black Jet Fuel Round Spout Cap Assembly
014206	Red Aviation Fuel Round Spout Cap Assembly

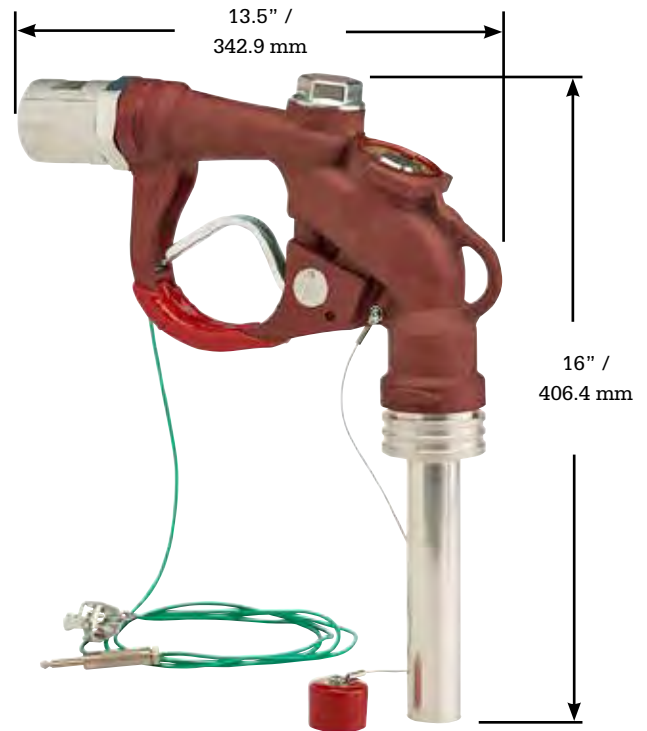

2325 Husky Way • Pacific, MO 63069
 (800) 325-3558 • Fax (636) 825-7300
www.husky.com • sales@husky.com

MADE IN THE U.S.A. 



AVIATION FUELING PRODUCTS

Aviation Swivels

Aviation Swivels



High volume swivels for over-the-wing fueling of aircraft.

- Prevents kinking and twisting of hose.
- Unique stainless steel ball bearing design provides easier joint movement during high pressure applications.
- Easier to angle the nozzle into fill openings.

NPT x BSPP

MODEL NO.	DESCRIPTION	SHIPPING WEIGHT LBS. (KG)
012799	1½" x 1½" BSPP Long Thread Single Plane Swivel	1.4 (.65)
012800	1¼" x 1½" BSPP Long Thread Single Plane Swivel	1.4 (.65)

BSPP x BSPP

MODEL NO.	DESCRIPTION	SHIPPING WEIGHT LBS. (KG)
013517	1¼" F x 1½" M Long Thread Single Plane Swivel	1.4 (.65)
013518	1½" F x 1½" M Long Thread Single Plane Swivel	1.4 (.65)

Construction

Body	Aluminum
Seals	Fluorocarbon

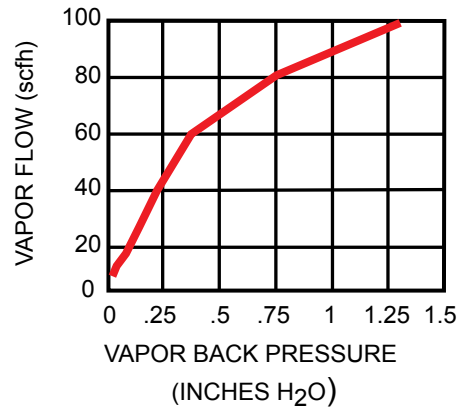

High volume swivels for over-the-wing fueling of aircraft.

Dimensions and System Options

AVIATION SWIVEL



2325 Husky Way • Pacific, MO 63069
 (800) 325-3558 • Fax (636) 825-7300
www.husky.com • sales@husky.com

MADE IN THE U.S.A. 



Aviation Spouts

Falcon Spouts



Spout assemblies.

- Replacement spout assemblies for nozzles that attach to the nozzle with a nut.
- Replacement spout assemblies for nozzles that attach to a nozzle with a quick disconnect.
- Duck bill spout assemblies for use with jet fuel only.
- Round spout assemblies for use with both aviation and jet fuel.

Falcon Nut Spout Assemblies

MODEL NO.	DESCRIPTION	SHIPPING WEIGHT LBS (KG)
012946	Duck Bill Spout Assembly for Jet Fuel	.6 (.27)
012948	Round Spout Assembly for Aviation and Jet Fuel	.5 (.23)

Falcon Quick Disconnect Spout Assemblies

MODEL NO.	DESCRIPTION	SHIPPING WEIGHT LBS (KG)
012947	Duck Bill Spout Assembly for Jet Fuel	.5 (.23)
012949	Round Spout Assembly for Aviation and Jet Fuel	.5 (.23)



012946



012947



012948



012949

Falcon Nut Spout Assembly

Falcon Quick Disconnect Spout Assembly



Spout assemblies.

Dimensions



7.80" /
198.1 mm

012946
012947

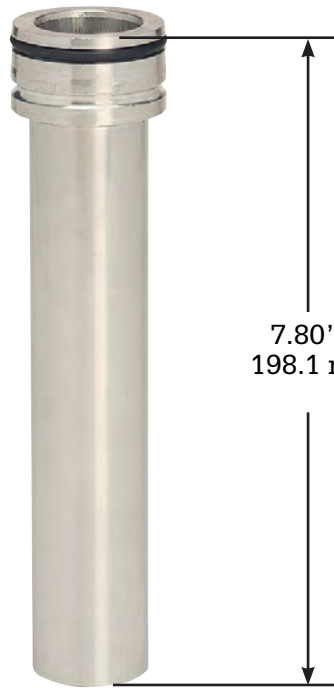

7.80" /
198.1 mm

012948
012949



2325 Husky Way • Pacific, MO 63069
(800) 325-3558 • Fax (636) 825-7300
www.husky.com • sales@husky.com

MADE IN THE U.S.A. 



Aviation Strainers

Aviation NPT Strainer



Strainer for over-the-wing fueling of aircraft.

- Easy to remove and clean fuel 100 mesh SS fuel filter assembly.
- Suitable for aviation fueling and other compatible fluids.
- Complies with IE1540 and NPA 407.
- Simple Male NPT x Female NPT strainer adaptor for multipurpose uses in fluid transfer.

Strainer

MODEL NO.	DESCRIPTION	SHIPPING WEIGHT LBS. (KG)
014024	3/4" NPT F x 3/4" NPT	1.5 (.8)

Construction

Body	Aluminum
Strainer	Stainless Steel
Inlet	3/4" (19mm) NPT threads





Aviation NPT Strainer

Strainer for over-the-wing fueling of aircraft.

Dimensions



2325 Husky Way • Pacific, MO 63069
(800) 325-3558 • Fax (636) 825-7300
www.husky.com • sales@husky.com

MADE IN THE U.S.A. 